



Multi jet Dry dial external regulation cold water meter(LXSG-15-40)

Characteristic:

1. High accuracy, magnetic drive, dry counter ensures long time clear reading
2. The Impeller is the only moving parts in contact with water made of high quality anti-corrosion material.
3. Non return valve to avoid the reserve flow rate as option;
4. Pulse output as option
5. Acrylonitrile Butadiene Styrene plastic(Uvioresistant, non-toxic,corrosion resistant)
6. IP68 protection level

Working condition(s):

Water temperature 0.1~30°C, working pressure≤1.0MPa. (T50,1.6Mpa for option)

Figurative diagram:

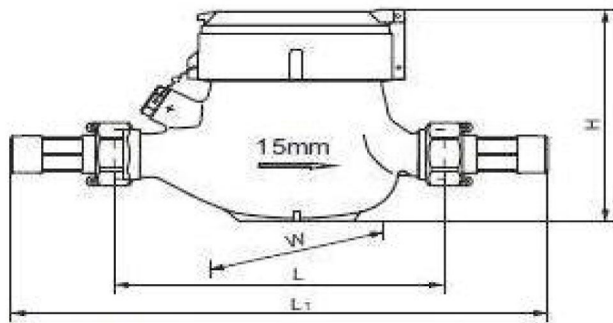

Shape dimension & weight:

Diameter (DN)	Length (mm)		Width (mm)	Height(mm)	Connection thread		Weight (Kg)
	L1	L			d	D	
15	259	165	96	106	R1/2	G3/4 B	1.26
20	294	190	96	107	R3/4	G1 B	1.5
25	382	225	101	114	R1	G1 1/4 B	2.48
32	385	230	101	114	R1 1/4	G1 1/2 B	2.81
40	430	300					4.89

Main technical parameters & Accuracy:

Diameter (DN)	Q max (Q ₄)	Q n (Q ₃)	Qt(Q ₂) Q ₂ /Q ₁ =1.6 m ³ /h				Q min(Q ₁) Specific value Q ₃ /Q ₁ m ³ /h				Min. reading	Max. reading
	Q ₄ /Q ₃ =1.25 m ³ /h		R80	R100	R125	R160	R80	R100	R125	R160	m ³	m ³
15	3.125	2.5	0.05	0.04	0.032	0.025	0.032	0.025	0.02	0.016	0.00005	99999
20	5	4	0.08	0.064	0.05	0.04	0.05	0.04	0.032	0.025	0.00005	99999
25	7.875	6.3	0.126	0.1	0.08	0.063	0.08	0.063	0.5	0.4	0.00005	99999
32	12.5	10	0.2	0.16	0.125	0.1	0.125	0.1	0.08	0.063	0.00005	99999
40	20	16	0.32	0.256	0.2048	0.16	0.2	0.16	0.128	0.1	0.00005	99999

Allowable error of indication & error Curve:

From Q₁ inclusive up to but excluding Q₂ is ± 5%;

From Q₂ inclusive up to and including Q₄ is ± 2% for T30 and ± 3% for T50 ;

Pressure Loss Curve

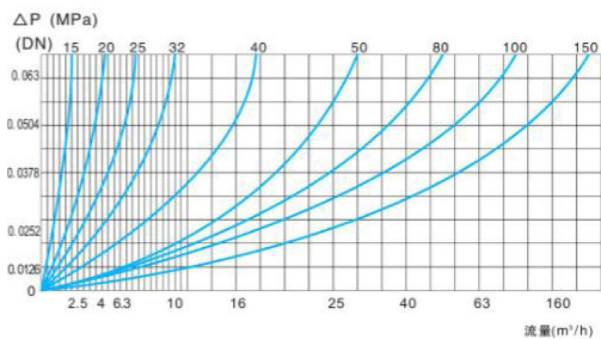

Flow Error Curve

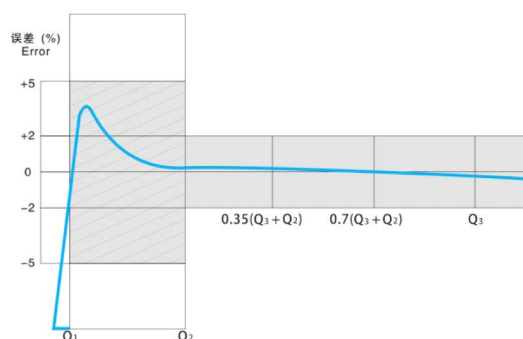

Installation and maintenance instructions

1. Choose the correct water meter according to size, flow rate and pressure.
2. Mount the meter in a horizontal position, dial face upward, flow direction as shown by arrow on meter body.
3. Allow a 10xD straight pipe length upstream of meter. 5xD straight pipe length downstream of meter.(D being nominal diameter of meter).
4. Ensure pipeline is clean and clear of debris before mounting meter.
5. Water exit side should always be higher than the meter.
6. For small size water meter(DN15mm~40mm) : do not connect meter to pipe directly, use the 2 connectors provided at each end of meter for subsequent easy dismounting.
7. If meter is installed on the inlet piping to a boiler, ensure no back flow of hot water to the meter.
8. Unstable pressure in the pipeline may cause slight movement of the pointer and roller even when there is no flow.
9. Cold water meter : Water temperature $\leq 30^{\circ}\text{C}$; out-door temperature $\leq 50^{\circ}\text{C}$
Hot water meter : Water temperature $\leq 90^{\circ}\text{C}$
10. Working pressure $\leq 1.0\text{Mpa}$ Test Pressure $\leq 1.6\text{Mpa}$
11. To ensure accuracy of meter, maintenance worker of the national water board to be informed to re-adjust the meter and clean the pipeline once, every 2 to 3 years based on the water quality, or remove impurities and rust in the pipeline as these can block the filter to affect the meter's measuring accuracy.
12. The DN15~40 meter comes with 2 pieces of brass connector, 2 pieces of brass nut and 2 pieces of sealing washer.
13. The DN50~200 meter comes with flange terminations.

The meter is sealed after proof reading and warranted for 12 months from the date of delivery. Warranty of the meter is void if the seal is broken.